



V3 Face Valve

Product Data Sheet

The V3 face valve is designed for use on a VersaPump 3 (V3). This valve is designed to be mounted on a V3 pump and be used with a Kloehn V3 syringe. These valves are rated to 100 psi and are used in a variety of clinical, medical, and analytical instrumentation applications. Face valves are highly inert to most chemistry and are designed for long life in most conditions. The valves are offered in two basic flow types, Distribution and Non-Distribution flow patterns.

Physical

- Valve Overall Dimensions
 - Diameter: 1.40 in.
 - Length: 1.78 in.See valve interface dimensions below
- Mass: 30 grams

Environmental

- Operating Temperature: 10°C to 40 °C
- Operating Humidity of 5% to 95% relative humidity, non-condensing at 40 °C
- Storage Temperature of -25 °C to 85 °C
- WEEE & RoHS compliant

Mechanical

- Orifice Diameter: See table for available diameters
- Port Specifications: ¼-28 flat bottom threaded ports, .245" deep
- Rated pressure: Vacuum* to 100 psi
- These valves are directional flow valves and are not intended as shut-off valves.
- These valves are not intended as pressure relief valves
- Syringe Locking Set Screw Torque: 1.0 in-lbs.
- Valve Mounting Hardware Torque***: 5.0 in-lbs.

Chemical

- Wetted Materials: PPS (Polyphenylene Sulfide), XP-113 (PEEK-Graphite Blend), Teflon

Valve Types

- Distribution – A distribution valve distributes fluid from the syringe to the various ports on the valve. Fluid may be drawn into the syringe from a given port and dispensed out of another port. Distribution valves have a flow path configuration that connects the syringe port to the various fluid ports. The number of ports on the valve is determined by the number of ports the syringe can distribute fluid to. The syringe port does not count as one of the ports on a distribution valve.
- Non-Distribution – A non-distribution valve connects adjacent ports on a valve to allow fluid to flow between them. Fluid may be drawn into the syringe only from one of the adjacent ports. Non-distribution valves allow a “bypass” fluid path where the fluid flows through the valve without entering the syringe. The number of ports on the valve is determined by the number of possible fluid paths. The syringe port counts as one of the ports on a non-distribution valve.

Valve Interface Dimensions

6-Way valve shown

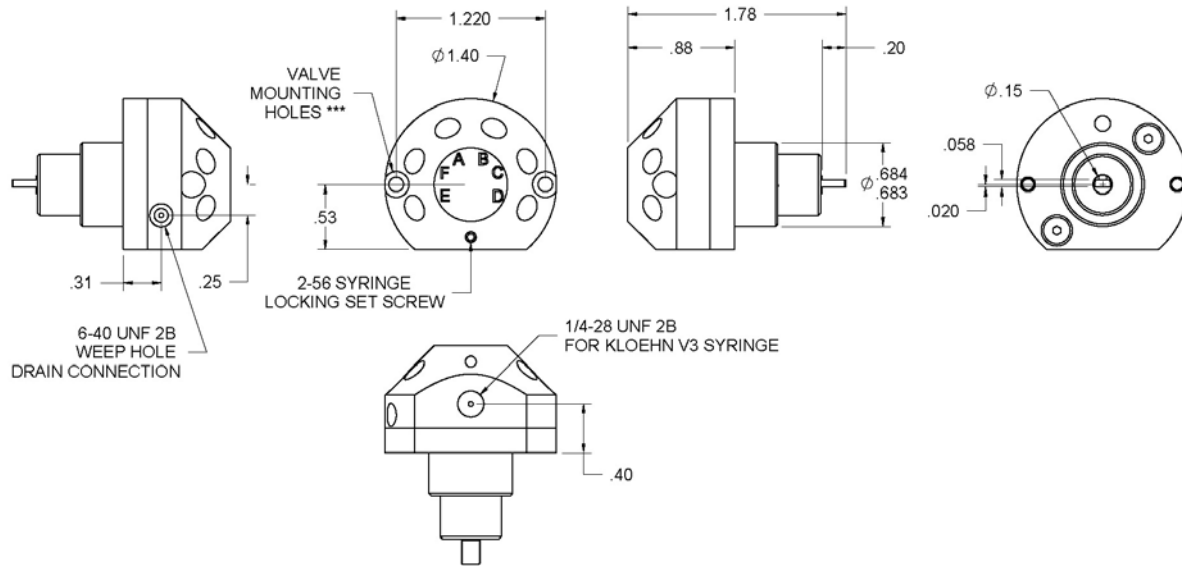

Valve Types and Port Configurations							
P/N	Orifice Diameter	Valve Type	Number of Ports	P/N	Orifice Diameter	Valve Type	Number of Ports
23324	0.059	3-Way Distribution	3	23562	0.059	3-Way Non-Distribution	3
24643	0.020	4-Way Distribution	4	23563	0.059	4-Way Non-Distribution	4
23325	0.059	4-Way Distribution	4	Optional Accessories			
23326	1mm	5-Way Distribution	5	24528	Weep Hole Fitting - PEEK		
23327	1mm	6-Way Distribution	6	24529	Weep Hole Fitting - Stainless Steel		
				18659	Port Plug Screw, use with seal p/n 18781		

* Vacuum pressure: -25inHg maximum at 2750ft elevation (1psia max).

** Custom ports, wetted materials and configurations are available upon request. See your local salesman for more information.

*** Mounting hardware supplied with the valve.